

This article was downloaded by:

On: 26 January 2011

Access details: *Access Details: Free Access*

Publisher *Taylor & Francis*

Informa Ltd Registered in England and Wales Registered Number: 1072954 Registered office: Mortimer House, 37-41 Mortimer Street, London W1T 3JH, UK



Liquid Crystals

Publication details, including instructions for authors and subscription information:

<http://www.informaworld.com/smpp/title~content=t713926090>

Relationship between lens properties and director orientation in a liquid crystal lens

S. Sato^a; T. Nose^a; R. Yamaguchi^a; S. Yanase^a

^a Department of Electronics, Akita University, Akita-city, Japan

To cite this Article Sato, S. , Nose, T. , Yamaguchi, R. and Yanase, S.(1989) 'Relationship between lens properties and director orientation in a liquid crystal lens', *Liquid Crystals*, 5: 5, 1435 – 1442

To link to this Article: DOI: 10.1080/02678298908027781

URL: <http://dx.doi.org/10.1080/02678298908027781>

PLEASE SCROLL DOWN FOR ARTICLE

Full terms and conditions of use: <http://www.informaworld.com/terms-and-conditions-of-access.pdf>

This article may be used for research, teaching and private study purposes. Any substantial or systematic reproduction, re-distribution, re-selling, loan or sub-licensing, systematic supply or distribution in any form to anyone is expressly forbidden.

The publisher does not give any warranty express or implied or make any representation that the contents will be complete or accurate or up to date. The accuracy of any instructions, formulae and drug doses should be independently verified with primary sources. The publisher shall not be liable for any loss, actions, claims, proceedings, demand or costs or damages whatsoever or howsoever caused arising directly or indirectly in connection with or arising out of the use of this material.

Relationship between lens properties and director orientation in a liquid crystal lens

by S. SATO, T. NOSE, R. YAMAGUCHI and S. YANASE

Department of Electronics, Akita University, Tegatagakuen-cho 1-1, Akita-city,
010 Japan

Lenses with a homogeneously aligned liquid crystal having a Fresnel structure have been prepared by using a nematic with a positive dielectric anisotropy. Their focal length can be varied continuously from the value f_e for an extraordinary ray to f_o for an ordinary ray by applying an electric field across the lens cell. The effective refractive index of the lens where the director is aligned perpendicular to the grooves of the Fresnel structure becomes smaller than when the director is aligned parallel to the grooves. Then the liquid crystal lens has a characteristic aberration which could not be observed in a conventional glass lens; that is, the focal length of the lens becomes different according to the incidence of rays on the different parts of the lens. The properties of the liquid crystal lens can be improved by making the director orientation axially symmetric, in the form of a concentric circle, but the polarization component rotated 90° from the incident extraordinary ray appears when the voltage is applied across the lens cell. This phenomenon is discussed in relation to the optical properties and the director orientation in a liquid crystal prism cell.

1. Introduction

Homogeneously aligned liquid crystal cells shaped like a plano-convex lens or a plano-concave lens have been made by using a nematic with a positive dielectric anisotropy [1]. Their focal length can be varied from the value f_e for an extraordinary ray to f_o for an ordinary ray by applying an electric field across the lens cell. The response and recovery properties of the liquid crystal lens were very slow and the transmission of incoming light was reduced by the absorption and/or scattering effect, because the thickness of the liquid crystal layer can become extremely large, for example, at the centre of a concave lens cell. A strong reduction of response and recovery times was attained and more transparent lenses were achieved by using Fresnel-type structures [2]. These variable focus lenses can be applied as eye glasses or for ophthalmological clinical use for people whose ability to adjust the focal lengths of their eyes has deteriorated and who need two or more pairs of glasses because of presbyopia or eye diseases such as cataracts and aphakic eyes [3].

However, the homogeneously aligned liquid crystal lens has a characteristic aberration which does not occur in conventional glass lenses, due to the anisotropy of the liquid crystal. Here relationships between the lens properties such as focussing profiles and director orientation in the homogeneously aligned liquid crystal lens are investigated. In order to improve the lens properties, a liquid crystal lens with axially symmetric director orientation is prepared, its properties have been measured, and characteristic problems which occurred in the present lens configuration are described.

2. Experimental procedure

The nematic liquid crystal E7 (Merck) was used in this work; it was placed in cells constructed from an indium–tin oxide (ITO) coated glass plate and a concave, plastic (polymethylmethacrylate; PMMA) Fresnel lens. The refractive index of PMMA (1.49) is smaller than that of E7 ($n_o = 1.523$, $n_e = 1.748$ at $\lambda = 589$ nm); that is, the liquid crystal lens in this work becomes a convex lens. The pitch of the Fresnel lens was $200\ \mu\text{m}$ and its radius of curvature was 30 mm. The ITO coated surfaces were treated with a polyvinyl alcohol (PVA) solution, then the surface was rubbed unidirectionally or axially symmetrically. The structure and alignment of the liquid crystal in the Fresnel lens are shown schematically in figure 1. Two typical director profiles are shown where the liquid crystal director is aligned perpendicular to the grooves of the Fresnel structure (along the direction a–a') or parallel to the grooves (along the direction b–b').

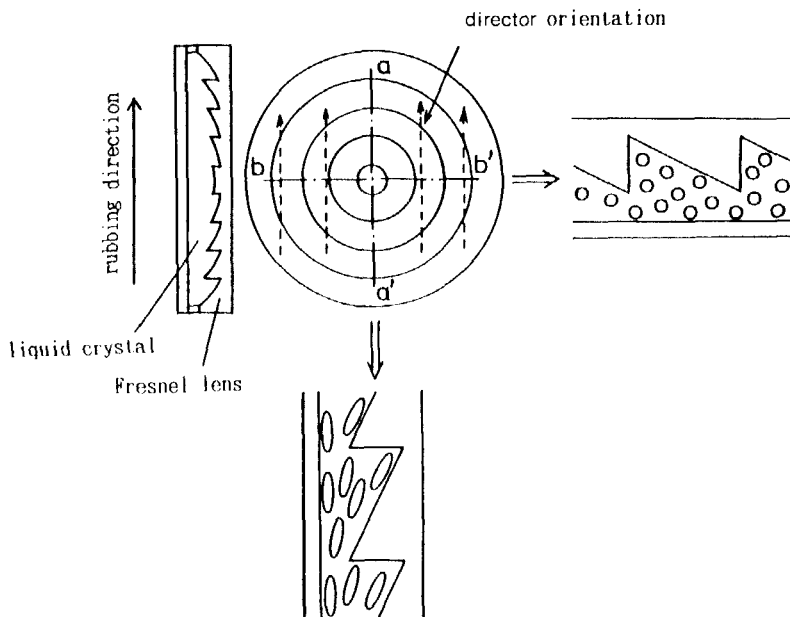

Figure 1. A homogeneously aligned liquid crystal lens and the director orientation in the cell.

The experimental set-up for measuring the lens properties is shown in figure 2. A collimated light beam (He–Ne laser) passed through the liquid crystal lens was detected by a CCD linear array sensor (Toshiba TCD106C, the size of one element was $7\ \mu\text{m}$) mounted on an XYZ stage. The focusing profile was obtained from the output signal from the CCD by means of a digital oscilloscope and a personal computer (PC9801). A pinhole plate and a polarizer were placed on the surface of the liquid crystal lens and the lens properties were measured for different incidence of rays on the different parts of the lens. Measurements were made at room temperature.

3. Results and discussion

The focusing profiles of light beams through the pinholes aligned along the direction a–a' or the direction b–b' in the homogeneously aligned liquid crystal lens are shown in figure 3; (a) at a point 40 mm ahead from the focal point, (b) in the

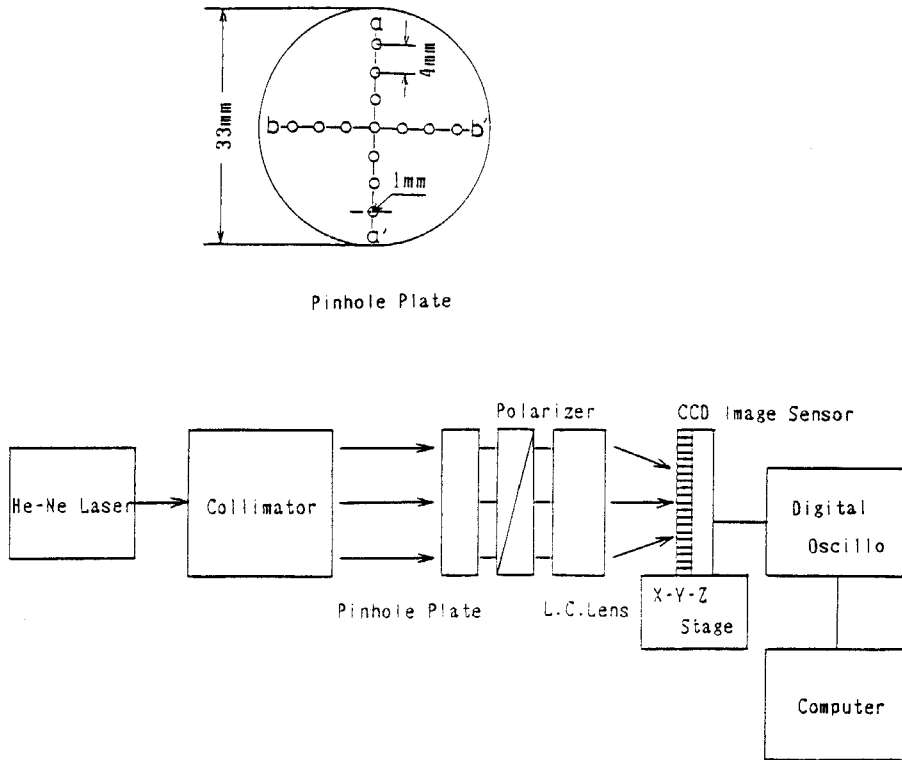

Figure 2. Block diagram for measuring the lens properties.

vicinity of the focal point and (c) 40 mm behind the focal point. Because of diffraction effects by the Fresnel structure and the pinholes, each beam passing through the hole consists of several sharp peaks. The refractive index of the lens where the director is aligned parallel to the groove of the Fresnel structure (direction $b-b'$) corresponds to the value of the extraordinary ray. On the other hand, the director orientation along the direction $a-a'$ is not parallel, but forms a splayed structure as shown in figure 1. Then the effective refractive index of the latter case (direction $a-a'$) becomes smaller than the former case (direction $b-b'$). The separation of the beams through the holes along the direction $a-a'$ is larger than that along the direction $b-b'$ in front of the focal point (see figure 3(a)), and is smaller behind the focal point (see figure 3(c)). The beams passing through the holes along the direction $a-a'$ are not focused yet at the focal point for the extraordinary ray (see figure 3(b)).

These effects become more remarkable as the distance from the centre of the liquid crystal lens increases and as the curvature of the Fresnel lens decreases. The focussing profiles of the homogeneously aligned liquid crystal lens for the light beam passing through the different pinholes are shown in figure 4. It is seen that the focal length for the beam through the outer part of the lens becomes longer than that for the beam through the inner part for the direction $a-a'$. On the other hand, the focal length for any beam is exactly the same for the direction $b-b'$. Therefore, the focal length of the liquid crystal lens is different according to the incidence of rays on the different parts of the lens. This characteristic aberration is usually observed in the homogeneously aligned liquid crystal lens and is independent of the Fresnel structure. When the

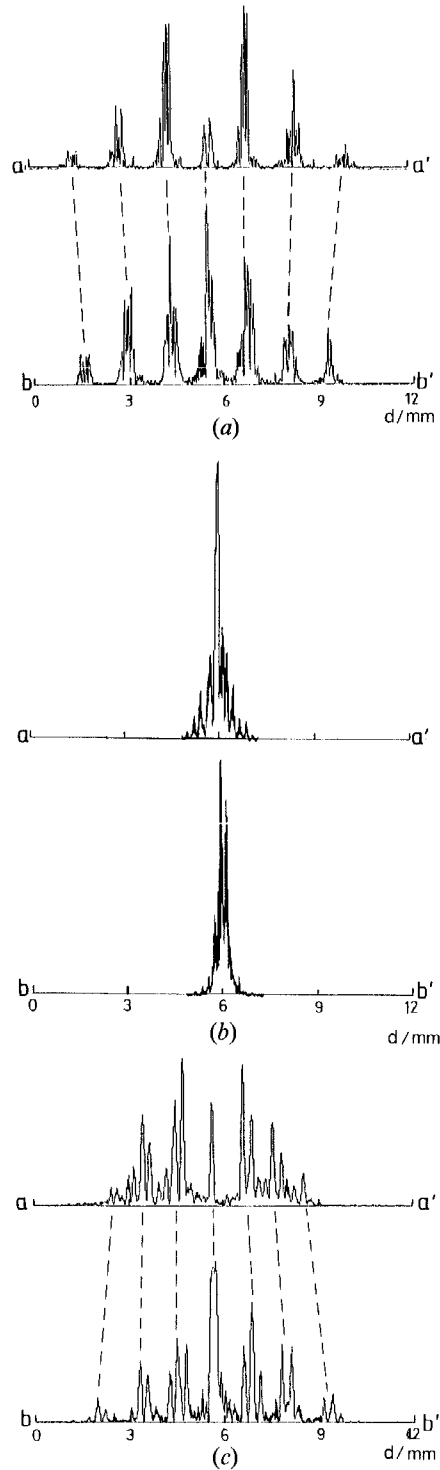

Figure 3. Focusing profiles of the homogeneously aligned liquid crystal lens. (a) 40 mm in front of the focal point, (b) in the vicinity of the focal point and (c) 40 mm behind the focal point. The distances a - a' and b - b' are measured in mm.

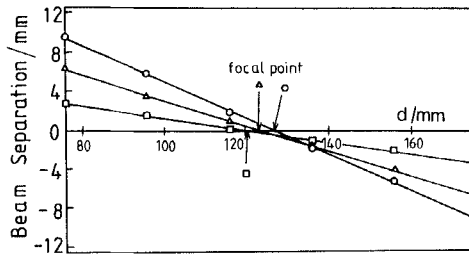

Figure 4. Beam separation versus distance from the liquid crystal lens; (O) the peripheral region, (Δ) the middle region and (\square) the central region.

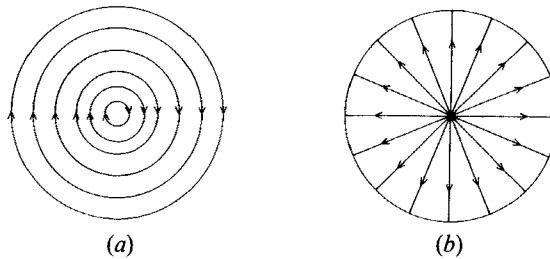

Figure 5. Axially symmetric director orientations. (a) Concentric circular orientation and (b) radial orientation.

voltage is applied across both ITO electrodes, similar phenomena are observed but the situation is rather complicated.

The properties of the liquid crystal lens with axially symmetric director orientation can be expected to be free from the directional dependence that is observed in the homogeneously aligned liquid crystal lens. Therefore, the properties of the liquid crystal lens can be improved by making the director orientation axially symmetric, in the form of a concentrically circular or a radial orientation as shown in figures 5 (a) and (b) [4]. Polarizers with axially symmetrical properties can be prepared by using methylene blue dyes [5]. The concentric circular director orientation was made by a conventional rubbing method. That is, cotton cloth or tissue was lightly pressed on the substrate fixed on a rotating table. However, it is rather difficult to make the director orientation uniformly radial, especially at the centre of the lens. In addition, the focal length of the liquid crystal lens with radial director orientation is not constant for the beam passing through any part of the lens; that is, it increases with increasing distance from the centre of the lens. We now describe the liquid crystal lens with concentrically circular orientation, and its focussing profiles are measured.

The results are shown in figures 6(a) and (b). It is seen that no directional dependence is observed in this lens. However, different problems are found when a voltage (≥ 1.5 V) is applied across this liquid crystal lens. The focussing profiles in the vicinity of the focal point are shown in figure 7 for an applied voltage of 4.5 V. A polarization component which is rotated 90° from the incident extraordinary ray occurs. This is a leaking component, as shown in figure 7 (b). The light beam of this component does not focus at the focal point of the lens, and its focal length is between that of the extraordinary component and the ordinary component. This leaking component is not observed in the liquid crystal lens with the radial orientation.

To clarify the phenomena, liquid crystal prism cells [6] with simpler structures than the liquid crystal lens were prepared using $15 \mu\text{m}$ thick mylar spacers between a

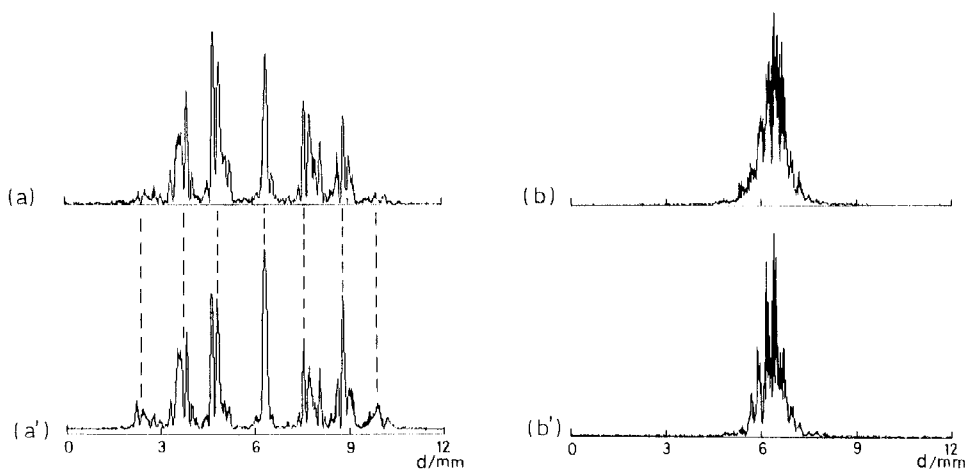

Figure 6. Focusing profiles of the liquid crystal lens with concentric circular orientations. (a) Along some diameters, d , 80 mm in front of the focal point, (a') along a diameter perpendicular to the direction shown in (a), (b) along the diameter shown in (a) in the vicinity of the focal point and (b') along the diameter shown in (a').

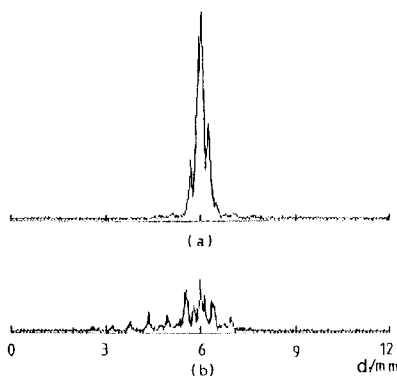

Figure 7. Focusing profiles of the liquid crystal lens with the concentric circular ray orientation for a voltage of 4.5 V applied across the lens cell. (a) For the extraordinary ray and (b) for the polarization component rotated 90° from the direction shown in (a).

Fresnel-type prism and a glass substrate; their light deflection properties were then measured. The polarization direction of the He-Ne laser light was parallel to the direction of the director. Relationships between the deflection angles and the applied voltages in this prism (with an inclination of 15°) is shown in figure 8. The director is parallel to the Fresnel grooves and this type of liquid crystal prism corresponds to the liquid crystal lens with the concentric circular orientation or along the direction b-b' in figure 1. Similar relations for the liquid crystal prism where the director is perpendicular to the Fresnel grooves are shown in figure 9 (corresponding to a liquid crystal lens with a radial orientation or along the direction a-a'). The leaking component for which the polarization is rotated 90° from the extraordinary ray is observed in figure 8 with the application of a voltage. Its deflection angle is smaller than that for the extraordinary component but it is larger than that for the ordinary component. In figure 9 no unusual component is observed.

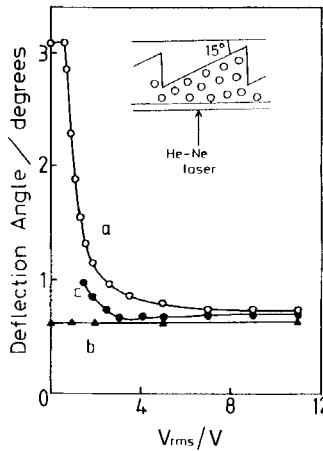

Figure 8. Deflection angles in the Fresnel-type liquid crystal prism cell as a function of the applied voltage. The direction of the director orientation is parallel to the Fresnel grooves (corresponding to the b-b' region). (a) For the extraordinary ray, (b) for the ordinary ray and (c) for the polarization component rotated 90° from the extraordinary ray.

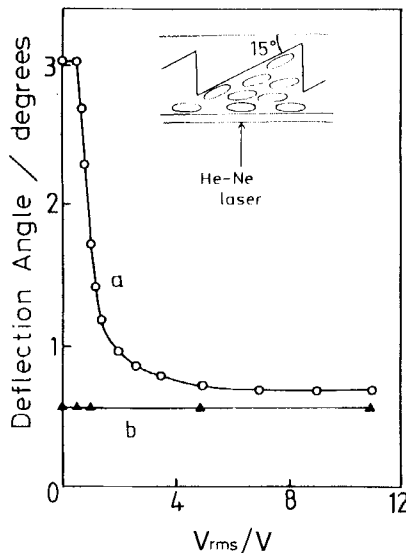

Figure 9. Deflection angles in the Fresnel-type liquid crystal prism cell as a function of the applied voltage. The director is perpendicular to the Fresnel grooves (corresponding to the a-a' region). (a) For the extraordinary ray and (b) for the ordinary ray.

In the prism type liquid crystal cell and the liquid crystal lens cell, the substrates of the cells are not parallel but are tilted with respect to each other. In consequence the lines of force (of the electric field) are not straight lines but recurved. While the incident light is going through the liquid crystal layer, its direction of polarization deviates from the director and an effective birefringence is induced for the incident extraordinary ray when the voltage is applied across the cell. Then the incident linearly polarized light becomes elliptically polarized and a component rotated 90° from the incident extraordinary ray appears. This component can be eliminated by

using another polarizer on the opposite side of the liquid crystal lens. Further work to clarify the details of these phenomena is in progress.

4. Conclusion

A variable focus liquid crystal lens has been prepared and the focal length of the lens can be varied continuously from f_e to f_o by applying an electric field. The homogeneously aligned liquid crystal lens has a characteristic aberration resulting from the optical anisotropy of the liquid crystal due to the unidirectional orientation of the director. The effective refractive index of the lens at the parts where the director is aligned perpendicular to the grooves of the Fresnel structure becomes smaller than where the director is aligned parallel to the grooves. In consequence the focal length of the lens becomes different according to the incidence of the rays on the different parts of the lens. The properties of the liquid crystal lens can be improved by making the director orientation axially symmetric, in the form of a concentrically circular orientation. However, another problem is observed in this lens type. The polarization component rotated 90° from the incident extraordinary ray appears and the focal length for this component is between that of the extraordinary ray and the ordinary ray when the voltage is applied across the cell. The problem can be removed by adding one more polarizer to the liquid crystal lens.

References

- [1] SATO, S., 1979, *Jap. J. appl. Phys.*, **18**, 1679.
- [2] SATO, S., SUGIYAMA, A., and SATO, R., 1985, *Jap. J. appl. Phys.*, **24**, L626.
- [3] SAKAI, F., TAKAHASHI, H., UCHIYAMA, H., and SATO, S., 1988, *J. ophthalmol. opt. Soc. Japan*, **9**, 30.
- [4] YAMAGUCHI, R., NOSE, T., and SATO, S., 1988, *Trans. IEICE Japan*, **J71-C**, 259.
- [5] NOSE, T., YAMAGUCHI, R., and SATO, S., 1988, *Trans. IEICE Japan*, **J71-C**, 1188.
- [6] SATO, S., and KIKUCHI, A., 1976, *Oyo Buturi*, **45**, 938.